

Reliable performance

The MECO EP Type-2 is a fully custom mechanical shaft seal. Its spring-loaded seal faces provide reliable sealing performance. Unlike standard stuffing boxes, the EP Type-2 is non-abrasive to the machine's shaft and can accommodate shaft runout. The EP Type-2 is available fully split for efficient installation and maintenance.

How it works

The EP Type-2's dynamic seal is formed between rotating, polymer seal faces and stationary, stainless-steel seal faces. A simple, yet robust elastomer drive ring keeps the seal's polymer seal faces locked in rotation with the machine's shaft.

The EP Type-2's seal faces are loaded by spring force, providing even and self-adjusting seal face pressure between larger, intermittent adjustments. Its seal cavity is pneumatically loaded by a compressed gas – typically air or an inert gas – to keep the rotating seal faces clear of product and debris. In addition, the purge gas helps isolate the process from the atmosphere.

Applications

The EP Type-2 seal is an effective sealing solution for vacuum, low pressure, and steady-state applications that experience moderate and infrequent thermal expansion or pressure changes. The EP Type-2 can be used on horizontal, inclined, and vertical shafts. Several common machines and process material applications are listed below.

EP Type-2 machine applications

- Single and twin shafted extruders
- Vacuum dryers
- Paddle blenders
- Sigma mixers

EP Type-2 process material applications

- Plastic processing
- Chemical processing
- Pharmaceutical processing
- Explosive environments

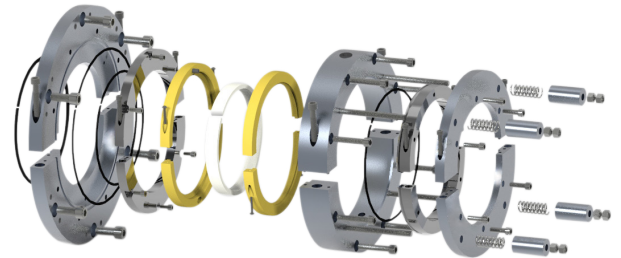

EP Type-2 features:

- ✓ Fully split
- ✓ Elastomer driven
- ✓ Self-adjusting
- ✓ Gas-purged

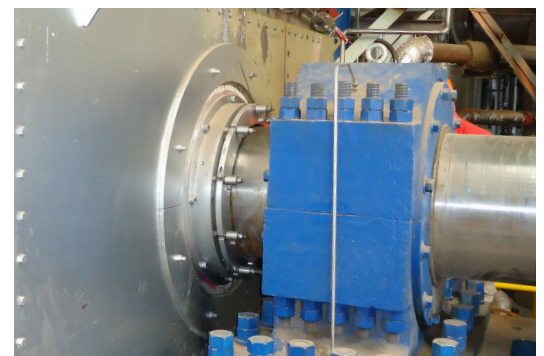
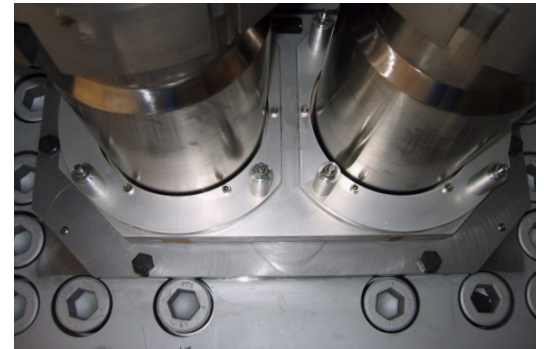

Sizing & material options

MECO's EP Type-2 is custom-engineered and manufactured to fit the needs of each application. Shaft sizes typically range from 1" (25 mm) to 17.5" (445 mm) and our engineers can accommodate most mounting arrangements.

The EP Type-2 seal is available in a variety of materials. The most common materials are listed below, but alternative materials may be available upon request. Contact us with your specific application requirements for a custom solution.

Metal component materials	O-ring materials	Rotor materials
304L stainless-steel	Viton®	MECO 3000 *
316L stainless-steel	Silicone	MECO 3400 **
17-4 stainless-steel	EPDM	Glass-filled PTFE
6061 aluminum		MECO 4001

* FDA Approved Polymers

** EU10/2011 Approved Polymers

Fully-split FOR EXTERNAL MOUNTING

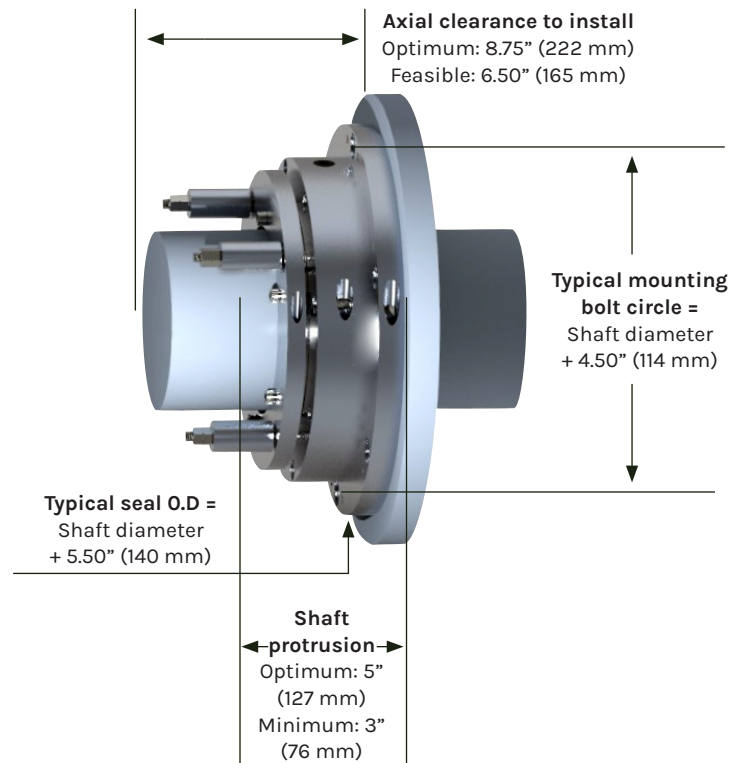

Maintenance

The EP Type-2's sealing performance can be easily monitored by maintenance and production personnel using the seal's pressure gauge system. The pressure gauge system is effective in quickly alerting maintenance and production personnel of a potential seal breach so that adjustments or repairs can be made before product leakage occurs.

Natural wear of the rotating seal faces is accounted for by the EP Type-2's self-adjusting spring force. When the spring gap increases beyond the specified range due to rotor wear, it can be quickly adjusted without disassembling the seal by tightening the spring retainer nuts. We offer fully split repair kits to replace all wear items within the seal.

Operating parameters

Woodex-MECO specializes in custom engineered seals designed for the particulars of each specific application. The mechanical capabilities of the EP Type-2 are dependent on the materials and processes involved in the application. We have a range of other seal models that may be more applicable if the EP Type-2 isn't a good fit for your application.



To learn more and to find out if the **EP Type-2** is the right seal for you, please give us a call, or submit an online application today!



woodex-meco.com | +1 207.371.2210 | sales@woodex-meco.com

216 Bay Point Road, Georgetown, ME 04548 U.S. | © Woodex Bearing Company, Inc. 2025